



CB 1565

LIST OF THE EXPLODED VIEWS



SHELL ASSY

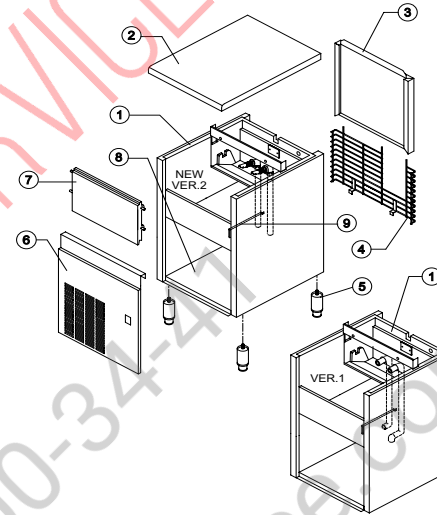

COOLING SYSTEM

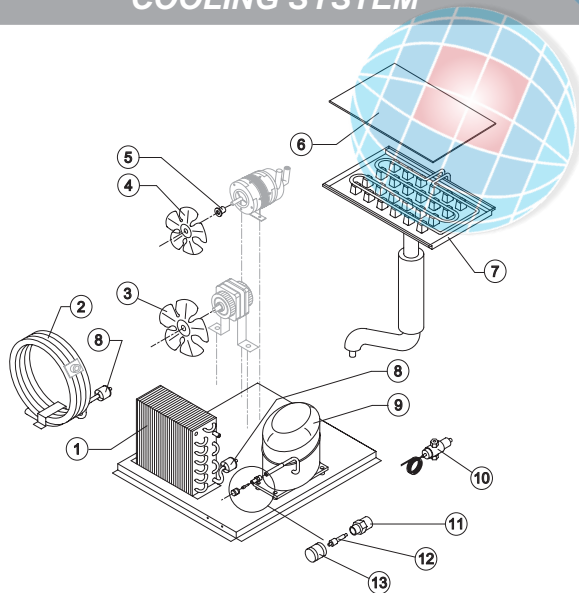

HYDRAULIC CIRCUIT

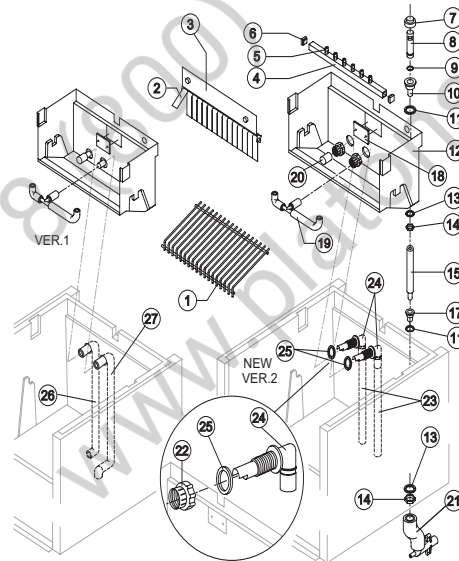

ELECTRIC PARTS

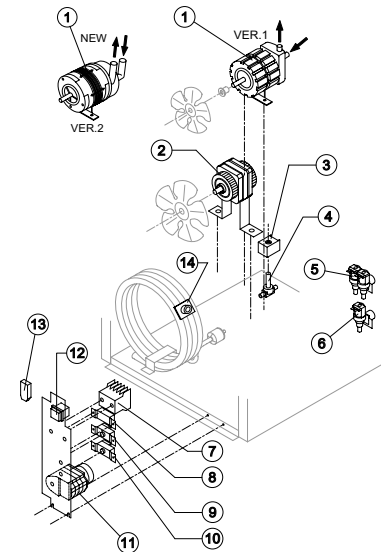

Rev. 3 - 2/7/2003

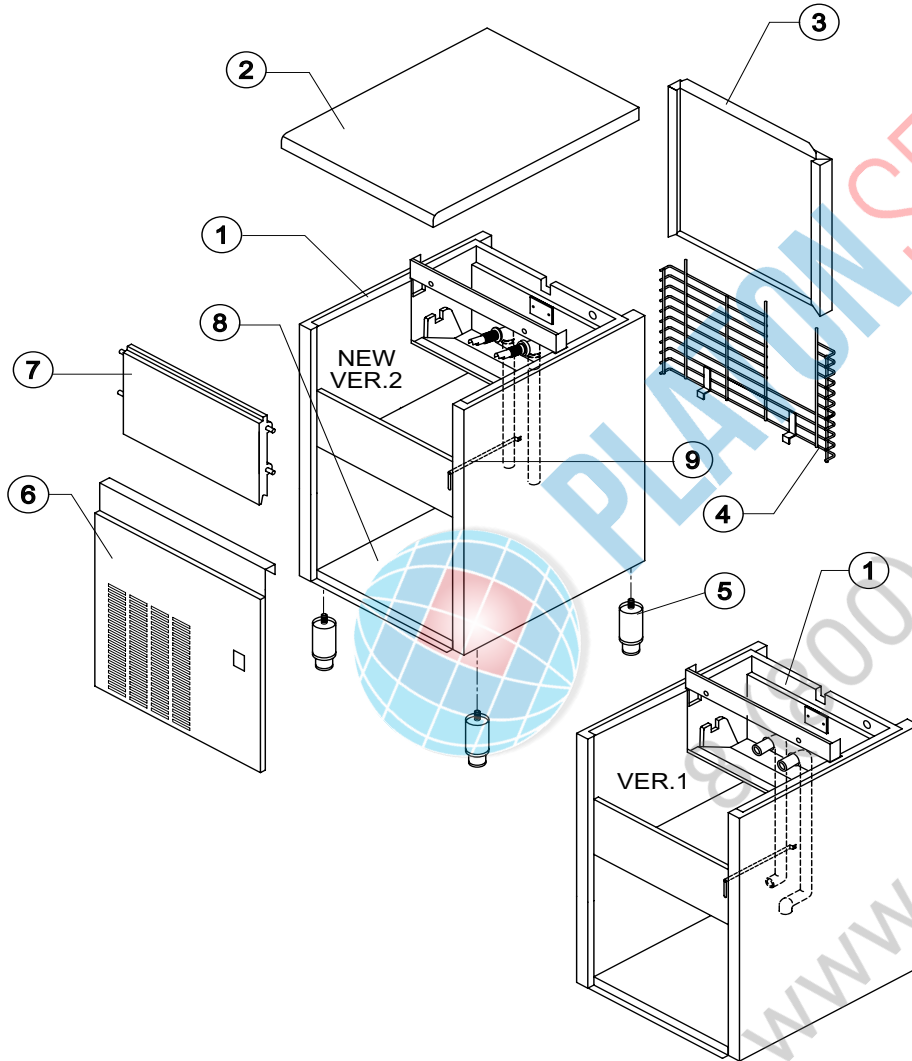

Ref.	Spare Description	Code
1	Foamed Cabinet Assy	See Table
2	Top Assembly	C22688
3	Back Panel Assembly	C21209
4	Back Grid	D12021
5	Stainless Steel Foot Adjustable	Current Version
5	ABS Foot	Till s/n. 142534
6	Front Grid Panel	22548
7	Door Assy	C10275
8	Base Plate	Current Version
8	Base Plate	Till s/n. 142534
9	Bulbe Thermostat Tube	20521

Ref. 1 - Foamed Cabinet Assy

Code	Condensation	Note
C11086A	Air	Version 2
C11086W	Water	Version 2
C11086/E		Version 1

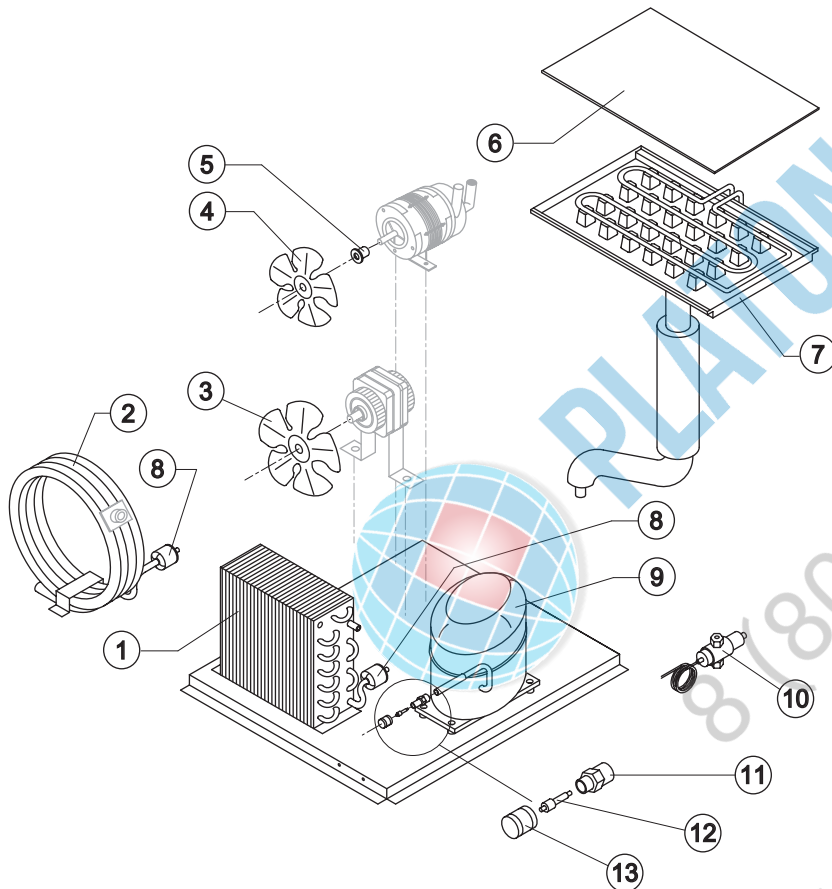

Common Parts

Ref.	Spare Description	Code
4	Suction Fan	10213
5	Hub for the Fan Fixing	10014
6	Evaporator Cover	10058
7	Evaporator	See Table
8	Solid Core Drier	14084
9	Compressor	See Table
11	Vacuum-Charge Valve Body	14007
12	Vacuum-Charge Valve Device	14005
13	Vacuum-Charge Valve Plug	14006

Parts for Air-Cooled Version Only

Ref.	Spare Description	Code	
1	Air Condenser	Current Version	20426
1	Air Condenser	Till s/n. 42925	20148
3	Suction Fan	Current Version	20407
3	Suction Fan	Till s/n. 42925	20153

Parts for Water-Cooled Version Only

Ref.	Spare Description	Code
2	Water Condenser	14081
3	Suction Fan	10213
10	Pressure Valve	20210

Ref. 8 - Evaporator

Kind of Cube	Code
18 g. (Standard)	D10214
33 g. (Big)	D10092
13 g. (Small)	D10126

Ref. 9 - Compressor

Tension	Code
220/240V 50 Hz	23438
220/230V 60 Hz	23466



CB 1565

HYDRAULIC CIRCUIT

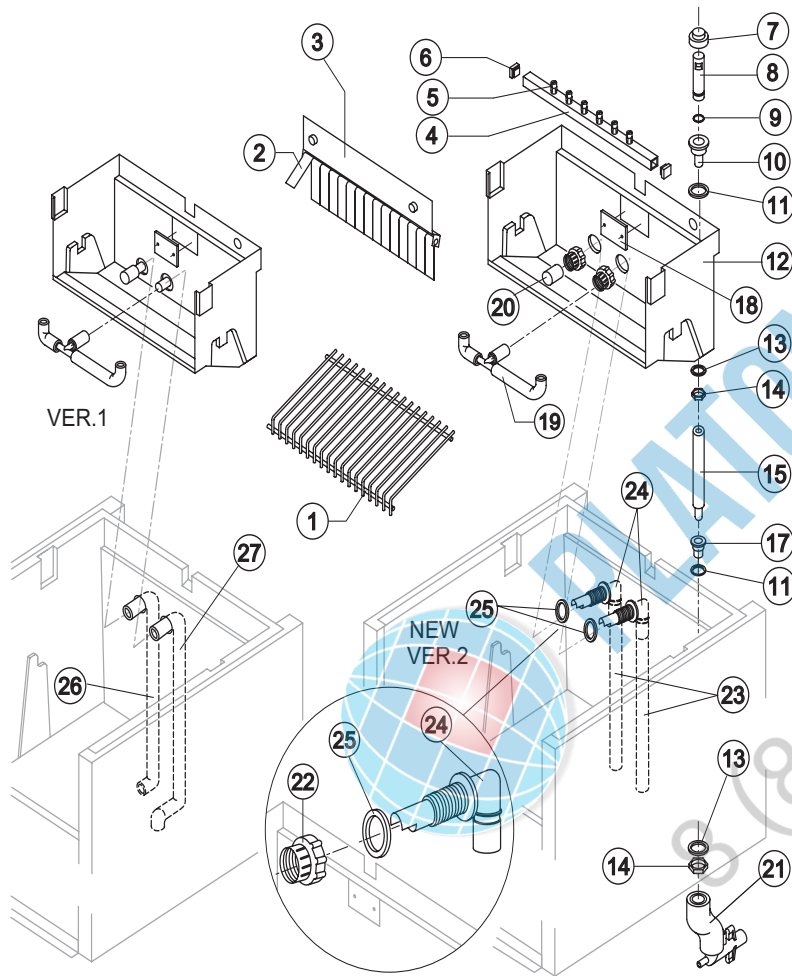

Common Parts

Ref.	Spare Description	Code	
1	Ice Cube Slides	See Table	
2	Flag	10005	
3	Flags Support Assy	C22134	
4	Sprayers Bar Assembly	See Table	
5	Sprayer	D20002	
6	Sprayers Bar Plug	10012	
7	Overflow Cap	10305	
8	Overflow Pipe	10133	
9	OR Gasket for Overflow Pipe	20233	
10	Overflow Pipe Nipple	10241	
11	Silicone Gasket	13006	
12	Inner Basin	10055	
13	Semirigid Polyethylene Gasket	13007	
14	Bin Discharge Nut	10096	
15	Overflow Pipe Assembly	C13110	
17	Plastic Nipple Water Outlet	10007	
18	Slide Keep Plate	10009	
19	Sprayers Bar Pipe Connection Assy	C13036	
20	Pump Suction Filter	20005	
22	Fitting Locking Ring	Version 2	10405
23	Pump Suction/Delivery Pipe	Version 2	13142
24	Fitting of the Pump Suction/Delivery Pipes	Version 2	10404
25	Gasket for Suction Line/Pump Delivery	Version 2	13143
26	Pump Suction Pipe	Version 1	13096
27	Pump Delivery Pipe	Version 1	13095

Rev. 3 - 2/7/2003

Ref. 1 - Ice Cubes Slide

Kind of Cube	Code
18 g. (Standard)	D12022
33 g. (Big)	D12033
13 g. (Small)	D12040

Ref. 6 - Sprayers Bar Ass.

Kind of Cube	Code
18 g. (Standard)	C20144
33 g. (Big)	C20157
13 g. (Small)	C20200

Parts for Air Cooled Version Only

Ref.	Spare Description	Code
21	Discharges Manifold	C10006

Parts for Water Cooled Version Only

Ref.	Spare Description	Code
21	Discharges Manifold	C26452



CB 1565

ELECTRIC PARTS

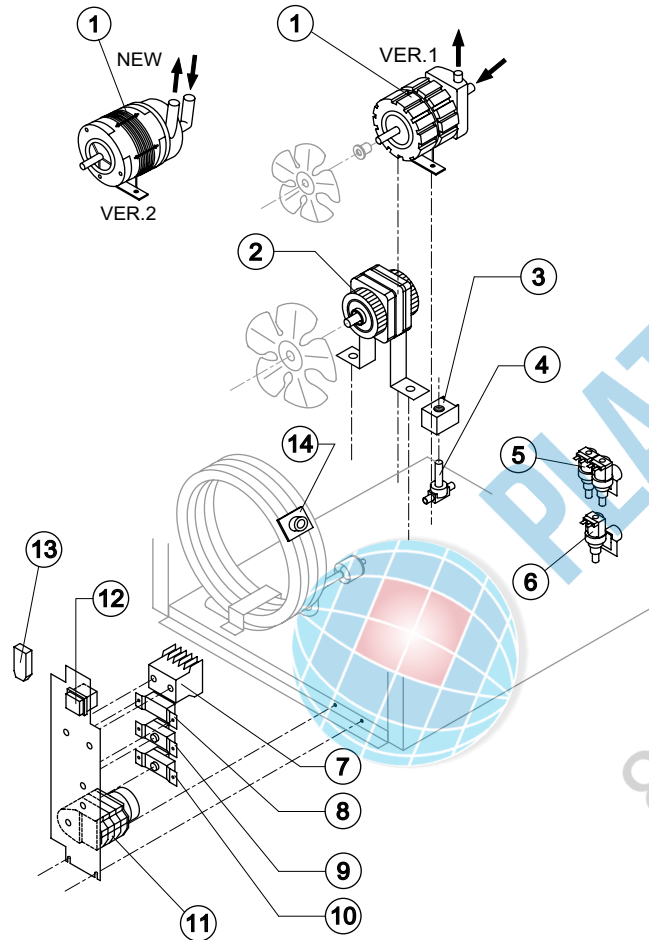

Common Parts

Ref.	Spare Description	Code
1	Pump	See Table
3	Hot Gas Coil	23091
4	Hot Gas Valve Body	20409
7	Contactor	23594
9	Bin Thermostat	23005
10	Evaporator Thermostat	23591
11	Timer	See Table
12	Green Light Switch	23327

Parts for Air-Cooled Version Only

Ref.	Spare Description	Code
2	Fan Motor	23121
6	Inlet Watervlve 1 Way	23108
8	Condenser Pressure Switch	23175
13	Anti Radio Interference Filter	Only 220V 50 Hz 23459

Parts for Water-Cooled Version Only

Ref.	Spare Description	Code
2	Fan Motor	23029
5	Inlet Watervlve 2 Ways	23138
14	Safety Thermostat	C23114

Ref. 1 - Pump

Tension	Version 1	Version 2
220/240V 50 Hz	23068	23462
220/230V 60 Hz	23068	23462

Ref. 11 - Timer

Tension	18g Cube	33g Cube	13g Cube
220/240V 50 Hz	23247	23248	23472
220/230V 60 Hz	23222	23396	23247

Rev. 3 - 2/7/2003